

SPARCO

AUTOMATIC WATER TREATMENT SYSTEM

Instruction Manual

Chlorine Pool-Care System for Pools up to 30,000 Gallons



Customer Service 800-222-0169
kingtechnology.com



WARNING

To minimize the risk of serious injury, death or damage, before installing or first using this equipment, read Instruction Manual and all safety labels and follow all safety instructions and precautions. Save manual for future reference.

TABLE OF CONTENTS

Sparco Introduction	3
Notes and Safety Information	4
Safety Labels on Sparco System	5
Installation Tips to Ensure Proper Performance	6
Sand Filter Installation with Nipple Kit and Flex Hose	7
DE and Cartridge Filter Installation With Flex Hose	8
Hard-Plumbed Installation	9
Step 1: Preparing the Pool	10
Step 2: Putting the System to Work	11
Step 3: Setting the Control Dial	12
Step 4: Routine Pool Care	13
Winterizing	14
Troubleshooting	15
Parts List	16
Maintenance - Replacing Control Dial O-Rings	17
Maintenance - Replacing Cap O-Rings and Knobs	18

For information on King Technology's entire product line, visit our website at kingtechnology.com

SPARCO

Thank you for choosing the Sparco Automatic Water Treatment System. This system will maintain a clean, clear swimming pool while you spend less time on maintenance and more time having fun! There are two parts to the Sparco System:

Part 1 **Sparco System**

The water treatment center that controls the flow of water through the Sparco Water Treatment Chamber.



For Pools up to
30,000 gallons.
Product # 01-02-5510

Part 2 **Sparco Chamber**

Pre-filled with chlorine tablets and fits inside the Sparco Water Treatment System.



Product # 01-04-5003

Notes and Safety Information

General Notes

These instructions contain information for the safe and proper operation of this Sparco System. Observe the following principles:

- Ensure that everyone using this Sparco System follows the instructions and safety precautions.
- Keep the instructions nearby and available for reference throughout the service life of this Sparco System.

These instructions do not provide for every possible contingency that might be encountered in connection with installation, operation or maintenance of this equipment. Should further information be desired or should particular issues arise which are not covered sufficiently in this manual, contact King Technology at 800-222-0169.





Explanation of the signal words

Signal words, which depict the probability and severity of harm, are used in these instructions. They are defined as follows:

Signal Word	Meaning
DANGER	Indicates an imminently hazardous situation which, if not avoided, will result in death, serious injury or major property damage.
WARNING	Indicates a hazardous situation which, if not avoided, could result in serious injury, death, or major property damage.
NOTICE	Indicates special instructions that are important but not related to physical injury hazards.

Explanation of the safety pictographs

The following pictographs illustrate the type and source of a hazard.

Pictograph	Type of Danger
	Safety Alert/General Hazard
	Explosion Risk
	Hazardous Pressure
	Flammable Fire Hazard

Identification of warnings

Warnings are intended to help you recognize risks and avoid death, injury or property damage. This is how warnings are identified:

 Signal Word
Pictographs
<p>Description of danger. Consequences if ignored.</p> <p>⇒ The arrow signals a safety precaution to be taken to eliminate or reduce the risk.</p>

Safety Label on Sparco System

Review this label before installing or operating this System. Contact King Technology at 800-222-0169 if this label is missing from your Sparco System.



Fire, explosion and high pressure hazards

To minimize the risk of serious injury, death or property damage while using the Sparco System:

- ⇒ Read, understand and follow all instructions and safety precautions in the manual, and on this Sparco System and on any label for chemicals used with this Sparco System including Sparco Chamber.

DANGER

- ⇒ Never use fast dissolving chlorine tablets, liquid bleach, or calcium hypochlorite in the Sparco System.
- ⇒ Never mix Trichlor chlorine tablets with Calcium Hypochlorite, or with any other form of concentrated chlorine or other chemicals.
- ⇒ Never add any other types of chlorine or shock treatments through the skimmer. These products should be added directly into the pool if required.
- ⇒ Do not contaminate the Sparco System or Sparco Chamber with dirt, organic matter, pool chemicals (such as calcium hypochlorite or pool shocks), fertilizers or other household chemicals. Contact between any of these substances and the Sparco System or Sparco Chamber, will result in a chemical reaction with the generation of heat, liberation of hazardous gasses and fire or explosion.

WARNING

- ⇒ Use only Sparco Chamber in the Sparco System. Never use bulk chemicals.
- ⇒ To prevent the build up of gas pressure in the Sparco System, be sure the pool return line valves are open – except when opening or servicing the unit.
- ⇒ Do not inhale fumes from the Sparco System or Sparco Chamber.
- ⇒ Avoid sparks, smoking, or any open flame near Sparco System or chemicals.
- ⇒ Do not exceed maximum operating pressure of 50 psi or maximum temperature of 104° F.
- ⇒ Do not remove the cap while under pressure. Always turn off pump and bleed off pressure before opening Sparco System.
- ⇒ Do not install automatic or fast shut off valves downstream of Sparco System.
- ⇒ Always install the Sparco System AFTER a heater (if applicable) on the return line.
- ⇒ Always install any additional sanitizing equipment AFTER and NEVER BEFORE the Sparco System is installed on the return line.
- ⇒ Do not permit children to use or climb on this product. This product must be positioned to prevent children from using it as a means of access to the pool.
- ⇒ Always stand clear of the Sparco System during pump start-up.
- ⇒ Replace Sparco System if you see signs of cracks, damage or degradation to the Sparco System body or cap.

NOTICE

- ⇒ Prior to pressurizing, check with your dealer to ensure your plumbing connections meet building codes.
- ⇒ Failure to properly winterize your Sparco System could result in freeze damage. (See page 14 for winterizing details.)

Installation Tips to Ensure Proper Performance

Before installing, read all directions carefully and contact your dealer for installation support.



WARNING

- Do not exceed maximum operating pressure of 50 psi.
- Do not install automatic or fast shut off valves downstream of feeder.
- Always install the Sparco System AFTER the heater (if applicable) on the return line.
- Always install any additional sanitizing equipment AFTER and NEVER BEFORE the Sparco System is installed on the return line.

1) If using a multi-speed pump, run pump for at least 6 hours per day at high speed (at least 40 gpm).

If the pump will run on low speed 24 hours per day or less than 6 hours per day on high speed, you must bleed the air while the pump is on by unscrewing the cap knob until water appears. Then screw the knob back on. Repeat this process each time the cap is removed for any reason.

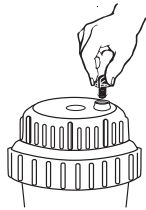

2) Install Sparco System with 4-8 psi back pressure.

Lower back pressures could result in under chlorination. Change the eyeball fittings in the return jets to a smaller size to increase back pressure. Contact King Technology at 800-222-0169 for a specially designed pressure gauge to determine back pressure at pool start-up.

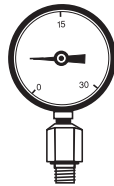

PN #01-22-4000

3) Special installation Requirements:

IMPORTANT: Over chlorination or damage to the Sparco System or other equipment could result if special installations A, B or C are not used in these situations.

- If water flow is higher than 80 gallons per minute (gpm), see diagram A.
- If an in-floor cleaner is included with pool, see diagram B, with two options. Preferred installation is Option 1 with two separate lines.
- If set-up is a pool and spa combination with common equipment, see diagram C.

Questions? Call Customer Service at 800-222-0169 Monday thru Friday, 8 am to 5 pm central standard time.

A. With High Flow Rate (greater than 80 gpm)

Install T-fittings exactly as shown.

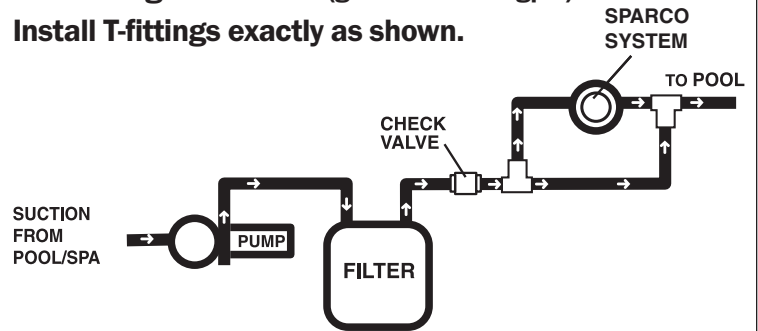

B. With In-Floor Cleaner - TWO OPTIONS

OPTION 1 - A Two-Line Installation

The best option is to have two lines. One line with pump, filter, heater and Sparco System and a second line with a separate pump for the in-floor cleaning system (filter optional).

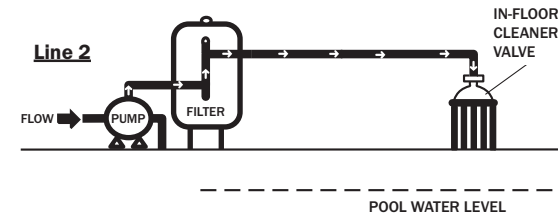
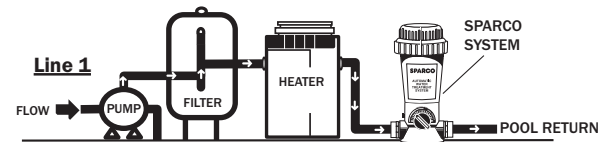

OPTION 2 - A 3-Way Valve Installation

3-way manual valve or 3-way motor valve plus controls

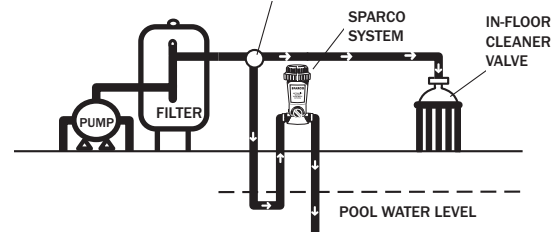

C. Pool and Spillover Spa Combination

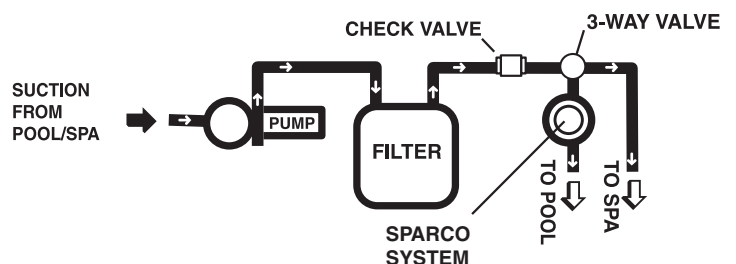

TOOLS NEEDED

Screwdriver

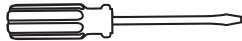

Pipe Wrench



MATERIALS NEEDED

Pipe Thread Sealant



Two 2" Threaded by 1 1/2" Threaded Male Adapters



Two Hose Adapters
1 1/2" x 1 1/2" x 1 1/4"



Two Sections of 1 1/2" or 1 1/4" Flex Hose (one provided with filter)

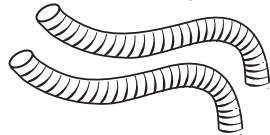

Two Hose Clamps



RECOMMENDED

4-8 psi Back Pressure

To avoid over or under chlorination, replace eyeball fittings in the return jets to a smaller or larger size to adjust back pressure. For best results use King Technology's pressure gauge, order part number 01-22-4000.

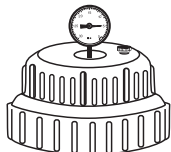

Sand Filter Installation with Flex Hose Only

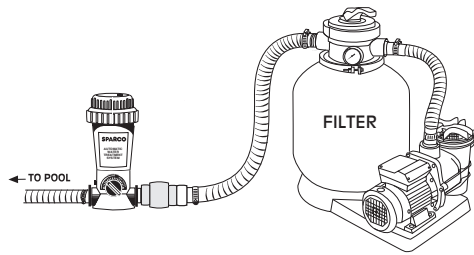

The Sparco System should always be installed between the filter and pool (or between heater and pool if applicable). Never install Sparco System before the heater or damage to the heater could occur.

1.

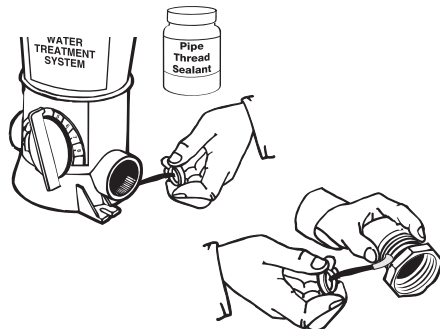

Following pipe thread sealant directions, brush sealant on to Sparco System threads in both ports and both male adapters.

DO NOT USE PIPE THREAD TAPE as the threads on these units are not suitable for this use and leaking or fitting failure could result.



2.

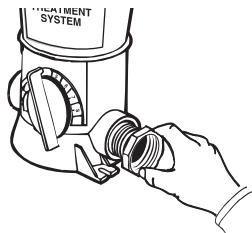

Screw a male adapter into each port of the Sparco System. Hand tighten. Finish tightening by turning 1 to 2 revolutions with a pipe wrench.

DO NOT OVER TIGHTEN.

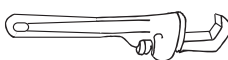

3.

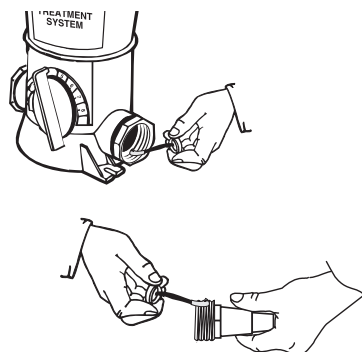

Apply sealant to threaded ends of both hose adapters and inside of both male adapters.

4.

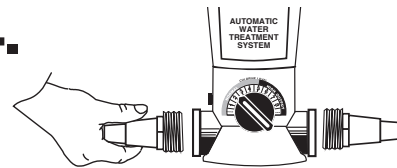

Screw adapters into each end of Sparco System. Hand tighten. Finish tightening by turning 1 to 2 revolutions with pipe wrench.

DO NOT OVER TIGHTEN.



5.

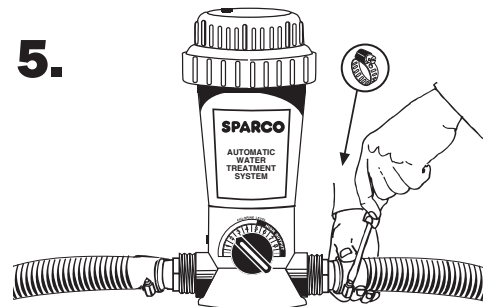

Attach the filter section of flex hose to one hose adapter and the return section of flex hose to the other hose adapter with clamps and tighten with screwdriver. Bi-flow valve design allows water flow in either direction.

6.

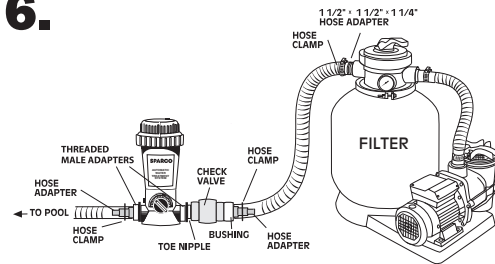

To prevent damage to heaters or filters, see your dealer about installing a **corrosion resistant check valve** which will reduce the back flow of chlorine gas when the Sparco System is turned off.

7.

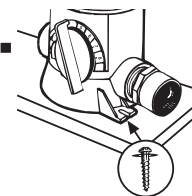

For better stability, Sparco System may be mounted on a treated wood base using **Phillips pan head screws**, one in front and one in back. If you

have questions about stability, please contact your dealer or King Technology.

TOOLS NEEDED

Screwdriver



Pipe Wrench



MATERIALS NEEDED

Pipe Thread Sealant



Two 2" Threaded by 2" Male Adapters



Two Hose Adapters
1½" x 1½" x 1¼"



Two Sections of 1½" or 1¼" Flex Hose (one provided with filter)

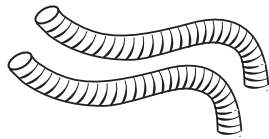

Two Hose Clamps



RECOMMENDED

4-8 psi Back Pressure

To avoid over or under chlorination, replace eyeball fittings in the return jets to a smaller or larger size to adjust back pressure. For best results use King Technology's pressure gauge, order part number 01-22-4000.

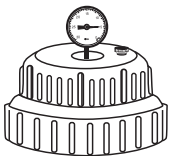

DE and Cartridge Filter Installation With Flex Hose

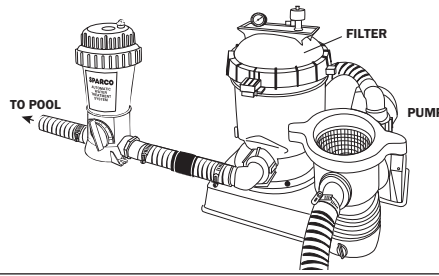

The Sparco System should always be installed between the filter and pool (or between heater and pool if applicable). Never install Sparco System before the heater or damage to the heater could occur.

1.

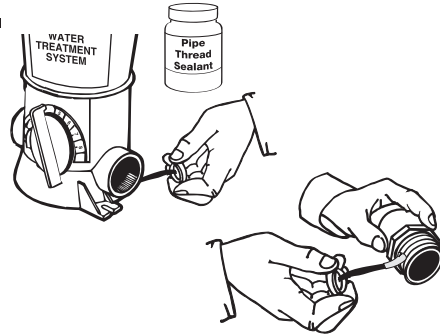

Following pipe thread sealant directions, brush sealant on to Sparco System threads in both ports and both male adapters.

DO NOT USE PIPE THREAD TAPE as the threads on these units are not suitable for this use and leaking or fitting failure could result.



2.

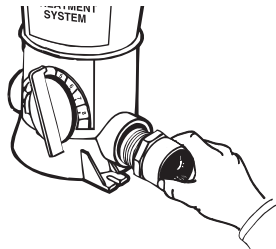

Screw a male adapter into each port of the Sparco System. Hand tighten. Finish tightening by turning 1 to 2 revolutions with a pipe wrench.

DO NOT OVER TIGHTEN.

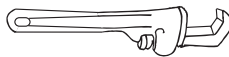

3.

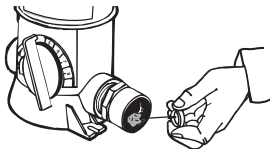

Apply sealant to threaded ends of both hose adapters and inside of both male adapters.

4.

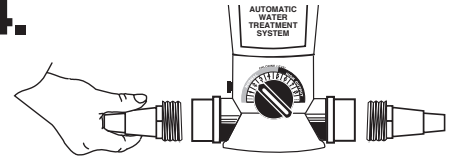

Screw adapters into each end of Sparco System. Hand tighten. Finish tightening by turning 1 to 2 revolutions with pipe wrench.

DO NOT OVER TIGHTEN.

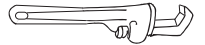

5.

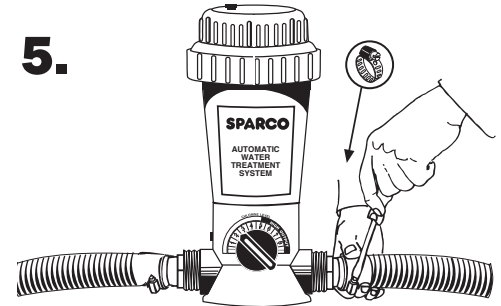

Attach the filter section of flex hose to one hose adapter and the return section of flex hose to the other hose adapter with clamps and tighten with screwdriver. Bi-flow valve design allows water flow in either direction.

6.

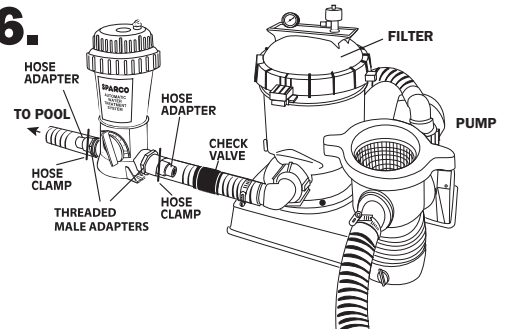

To prevent damage to heaters or filters, see your dealer about installing a **corrosion resistant check valve** which will reduce the back flow of chlorine gas when the Sparco System is turned off.

7.

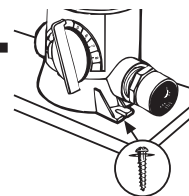

For better stability, Sparco System may be mounted on a treated wood base using **Phillips pan head screws**, one in front and one in back. If you

have questions about stability, please contact your dealer or King Technology.

TOOLS NEEDED

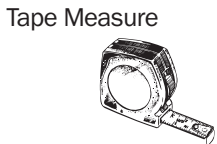
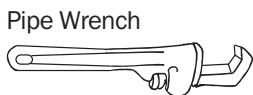

MATERIALS NEEDED

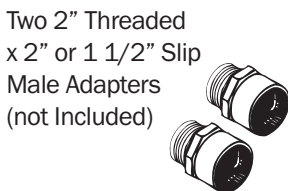
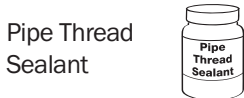

RECOMMENDED

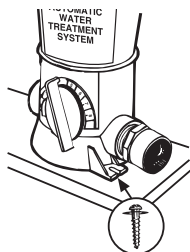

For better stability, Sparco System may be mounted on a treated wood base using **Phillips pan head screws**, one in front and one in back. If you have questions about stability, please contact your dealer or King Technology.

4-8 psi Back Pressure

To avoid over or under chlorination, replace eyeball fittings in the return jets to a smaller or larger size to adjust back pressure. For best results use King Technology's pressure gauge, order part number 01-22-4000.

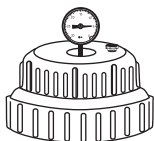

Hard-Plumbed Installation

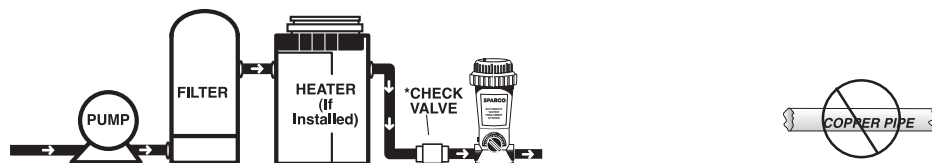

The Sparco System should always be installed between the filter and pool (or between heater and pool if applicable). Never install Sparco SYSTEM before the heater or damage to the heater could occur.

Do NOT install in copper pipe as chemical corrosion may lead to pipe failure.



Do NOT install an in-line Sparco System off-line.



Bi-flow valve design allows installation in either flow direction.

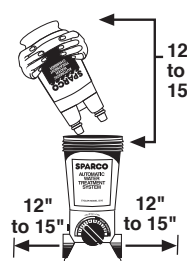

Allow a minimum of 12" above and on each side of the Sparco System to ensure room for easy replacement of Sparco Chamber.

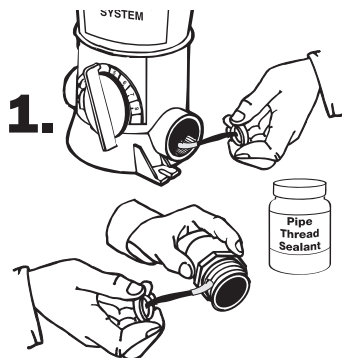

Following pipe thread sealant directions, brush sealant onto Sparco System threads in both ports and both male adapters.

DO NOT USE PIPE THREAD TAPE



Screw a male adapter into each port of the Sparco System. Hand tighten. Finish tightening by turning 1 to 2 revolutions with a pipe wrench. **DO NOT OVER TIGHTEN.**

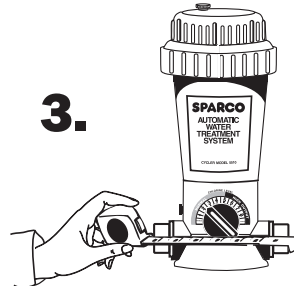
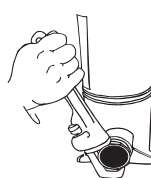

Measure the distance between the Sparco System male adapters and cut out a section of pipe 3" less than that dimension.

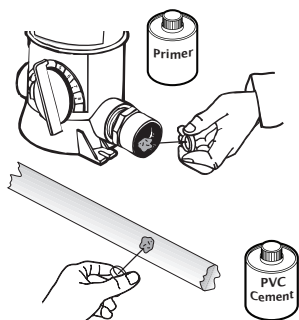

Following Primer directions, brush Primer on the inside of the male adapters and to ends of pipe. Repeat this process with PVC cement following manufacturer's directions on that product.

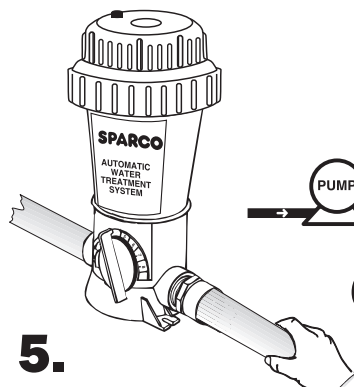

Insert PVC pipe into male adapters with a twisting action. Hold in place 5 to 10 seconds to bond.

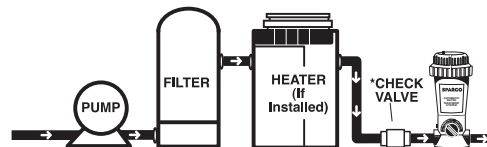

To prevent damage to heaters or filters, see your dealer about installing a **corrosion resistant check valve** which will reduce the back flow of chlorine gas when the Sparco System is turned off.

Step 1: Preparing the Pool

1.  Make sure the pool has adequate circulation. The total volume of pool water must completely circulate through the pump and filter at least 1 to 2 times per day. This usually requires 8 to 12 hours of circulation. Check with your dealer for the proper circulation time for your pool.

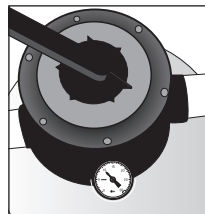
2.  Check the pool's filter gauge often and periodically clean filter per the manufacturer's directions. A dirty filter will slow the flow of water which could hamper proper circulation.

 **WARNING**
Do not exceed maximum operating pressure of 50 psi.

3. Check the Water Hardness of your fill water before adding to the pool. If calcium content is higher than 400 ppm, find a soft water source to fill your pool instead; otherwise water balance will be very difficult.

4.  Check for metals in the pool such as iron or copper. Before attempting water balance, these should be removed. See your dealer for a metal out or sequesterant and follow the label directions carefully.

5. Before beginning with any pool care program, you must first balance your pool water. Take a water sample to your local pool professional (or use a complete test kit) to test for the important Water Balance Guidelines.

IMPORTANT: Always follow printed instructions on the balancing chemical packages. Add balancing chemicals in small increments one at a time with circulation running. **For best results, wait 8-12 hours** before testing again and adding any additional balancing chemicals.

Water Balance Guidelines

pH:	7.2 – 7.8
Total Alkalinity:	80 – 120 ppm
Hardness:	200 – 400
Total Dissolved Solids:	<1500
Stabilizer:	20 – 80 ppm
Free Chlorine:	0.5 – 1.0 ppm

For best results in achieving water balance, follow steps **5a through 5e** in order.

5a. Take a water sample from the pool and dip a test strip into it.

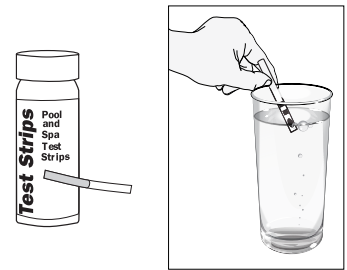

5b. Look at the **Total Alkalinity** reading first. Adjustments should be made to bring the Total Alkalinity in the range of **80 – 120 ppm** prior to making any adjustments to pH even if it throws pH off further.

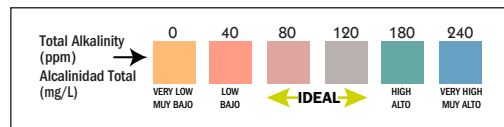

5c. After Total Alkalinity is in range, test for **pH**. It should be between **7.2 and 7.8**. If higher or lower, add a pH adjuster.

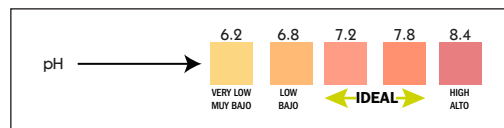

5d. Then test your Water Hardness again. If lower than 200 ppm, add Calcium Increaser. Always maintain 200-400 ppm.

5e. Lastly test for **stabilizer** or **conditioner levels**. Add conditioner if the level is below 20 ppm. This will prevent chlorine burn off. If stabilizer level is above 80 ppm, partially drain water and re-fill.

6.  Initially shock the pool with a **chlorine shock only** to rid the water of contaminants and establish a chlorine residual. Always follow the manufacturer's directions carefully. See the DANGER box below for important guidance on shocking.



DANGER

- Never add any other types of chlorine or shock treatments through the skimmer. These products should be added directly into the pool if required.
- Never use fast dissolving chlorine tablets, liquid bleach, or calcium hypochlorite in the Sparco System.

Step 2: Putting the System to Work



DANGER

Never use fast dissolving chlorine tablets, liquid bleach, or calcium hypochlorite in the Sparco System.



WARNING

Avoid sparks, smoking, or any open flame near Sparco System or chemicals.

IMPORTANT: Read the label on the Sparco Chamber carefully before using.

1.



Turn off pump. Turn dial to Minimum. This reduces the flow of water into the unit when the cap is open.

2.

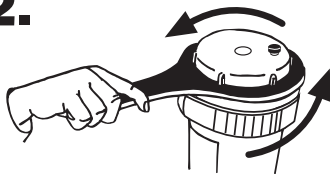

Open the cap. Use the cap tool included with Sparco System to loosen cap by hitting the handle with the flat of your hand counter clockwise. Stand back to allow any chlorine fumes to dissipate.

3. Cut handle from Sparco Chamber using a PVC cutting tool (KEEP OUT OF REACH OF CHILDREN)

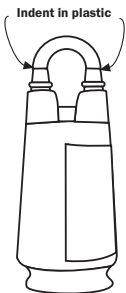

3a. Find the indent in the plastic.



PVC cutting tool available at local hardware stores.

3b. Place curved section of tool around the narrow end of one Sparco Chamber tower and line up blade on indent



3c. Squeeze the handles together. Repeat for other side.

Finished cut ends



3d. Make sure the blade comes straight across on the indent line for a clean cut.

3e. If openings are pinched together, open with fingers or re-cut closer to the colored screens inside Sparco Chamber. Leave at least 1/4" of plastic to fit into Sparco base.

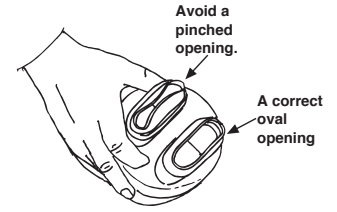

4.

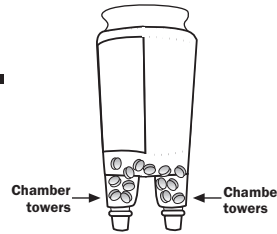

Invert Sparco Chamber and shake slightly until tablets fall into tower areas.

5.



Insert Sparco Chamber into Sparco System, lining up the openings in Sparco Chamber with keys in Sparco System.

NOTE: Openings are a different shape than keys.

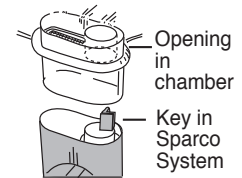

6.

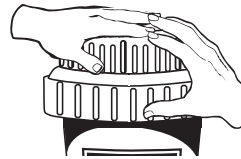

Replace cap by hand only. **DO NOT OVERTIGHTEN.**

DO NOT USE CAP TOOL TO TIGHTEN CAP. FOR REMOVAL ONLY.



7.



The Sparco Chamber is made of HDPE plastic. Non-refillable container. Do not reuse or refill this container. Offer for recycling if available. Rinse thoroughly before recycling or discarding in trash.

8.



Mark your calendar ahead for the approximate replacement times for the Sparco Chamber.

Step 3: Setting the Control Dial

This system is designed to work effectively with a variety of pool equipment as long as the following procedures are followed.

- Set control dial on Sparco System by matching up the parameters of your pool on the chart below. THIS IS A STARTING POINT ONLY and may need to be adjusted to fit your individual pool needs. See #2 below for adjusting directions.
IMPORTANT: If using a multi-speed pump, pump-run times of at least 6 hours per day at high speed are recommended for proper performance. **If running the pump at low speed only or on high speed less than 6 hours, please follow the 24 hour low-speed directions below.**

SINGLE-SPEED PUMP OR HIGH-SPEED PUMP-RUN TIME												
POOL SIZE Gallons	6 HOUR PUMP RUN TIME				12 HOUR PUMP RUN TIME				24 HOUR PUMP RUN TIME			
	PUMP SIZE				PUMP SIZE				PUMP SIZE			
	3/4 hp	1 hp	1 1/2 hp	2 hp	3/4 hp	1 hp	1 1/2 hp	2 hp	3/4 hp	1 hp	1 1/2 hp	2 hp
7,000	3.5	3.0	2.5	2.5 [^]	2.5	2.0	3.5 [^]	3.0 [^]	1.0	3.0 [^]	2.5	2.0 [^]
9,000	4.0	3.5	3.0	2.5	3.0	2.5	2.0	3.5 [^]	2.0	3.5 [^]	3.0	2.5 [^]
12,000	4.5	4.0	3.5	3.0	3.5	3.0	2.5	2.0	2.5	2.0	1.0	3.0
18,000	NR	4.5	4.0	3.5	4.5	3.5	3.0	2.5	3.0	2.5	2.0	1.5
25,000	NR	NR	4.5	3.5	NR	4.5	3.5	3.0	3.5	3.0	2.5	2.0
30,000	NR	NR	5.5	4.5	NR	5.0	4.5	3.5	NR	3.5	3.0	2.5

[^] Bypass installation recommended. See "Installation Tips" on page 6. NR- This pump size is not recommended for this size pool.

24 HOUR, LOW-SPEED PUMP-RUN TIME

In order to ensure proper performance when running the pump on low speed for 24 hours per day or high speed less than 6 hours per day, bleed the air while the pump is on by unscrewing the cap knob until water appears. Then screw the knob back on. Repeat this process each time the cap is removed for any reason. Set the control dial at 6 and follow the adjustment directions in Step 2 to determine the correct setting for your pool.

EXAMPLE

POOL SIZE Gallons	12 HOUR PUMP RUN TIME			
	PUMP SIZE			
	3/4 hp	1 hp	1 1/2 hp	2 hp
7,000	2.5	2.0	3.5 [^]	3.0 [^]
9,000	3.0	2.5	2.0	3.5 [^]
12,000	3.5	3.0	2.5	2.0
18,000	4.5	3.5	3.0	2.5
25,000	NR	4.5	3.5	3.0
30,000	NR	5.0	4.5	3.5

Find your starting dial setting by matching up the parameters of your pool on the above chart. An above ground pool with approximately 12,000 gallons, with a 1 1/2 horsepower pump running 12 hours a day, would require a starting setting of 2.5.

- 

For the first week test the pool water daily for free chlorine to ensure correct dial setting. Continue to test weekly throughout the season.

IMPORTANT: Control dial settings in excess of these recommendations could result in excess trichlor levels being discharged into the pool. This can result in bleaching or discoloration of areas around the pool inlet or in some cases bleaching or discoloration of the entire pool liner or paint. In addition, excess trichlor in the pool can create health hazards to bathers.



After each testing, adjust the dial up by 1/2 increment if the free chlorine reading has dropped or down by 1/2 increment if the reading has risen. Continue this process each day until the reading stabilizes at your desired level between 1.0- 3.0 ppm. Remember to adjust dial by 1/2 increments only.



Use the handle end of cap tool if the dial is hard to turn.

Step 4: Routine Pool Care



1. Run filtration system enough hours to circulate all water 1 to 2 times per day. More than that could result in over chlorination.



WARNING

To prevent the build up of gas pressure in the Sparco System, be sure the pool return line valves are open –except when opening or servicing the unit.

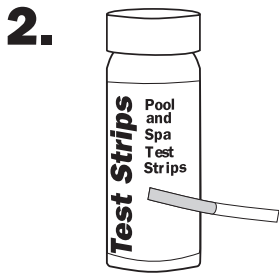

2. Regularly test water to maintain pH and Total Alkalinity.

NOTE: Water balance is affected by bather load, chemical usage, evaporation and the makeup of source water, so maintaining water balance regularly is important.



3. Maintain 1.0 - 3.0 ppm free chlorine level at all times.



DANGER

Do not contaminate the Sparco System or Sparco Chamber with dirt, organic matter, pool chemicals (such as calcium hypochlorite or pool shocks), fertilizers or other household chemicals. Contact between any of these substances and the Sparco Chamber will result in a chemical reaction with the generation of heat, liberation of hazardous gasses and fire or explosion.

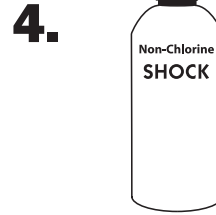

4. Shock the pool every week or as needed with a non-chlorine or chlorine shock.



DANGER

- Never add any other types of chlorine or shock treatments through the skimmer. These products should be added directly into the pool if required.
- Never use fast dissolving chlorine tablets, liquid bleach, or calcium hypochlorite in the Sparco System.

Winterizing

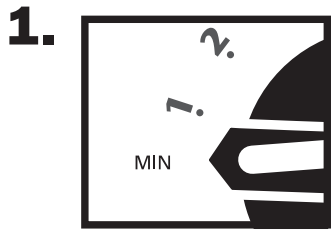

Turn pump off and turn dial to Minimum.

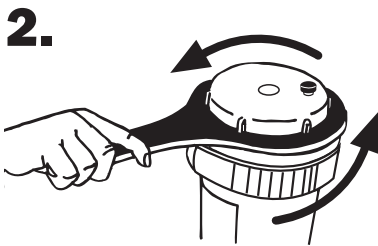

Remove cap.

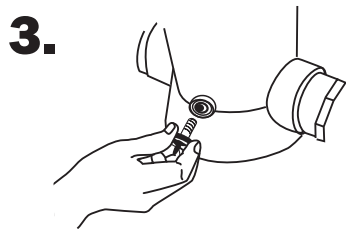

Unscrew knob in the back of Sparco System. Allow all water to drain.



Remove Sparco Chamber.



If the Sparco Chamber still contains chlorine, wrap in plastic bag and store in shed or cool, dry, well-ventilated location away from children, pets, cars, motorcycles or anything metal that can rust, pit, etc.



If empty, rinse and recycle.



WARNING

Avoid sparks, smoking, or any open flame near Sparco System, Sparco Chamber or chemicals.

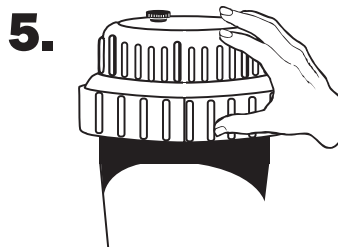

Replace the cap and knob loosely.

Troubleshooting

For help troubleshooting call King Technology at 800-222-0169.

Problem	Remedy		
<p>1. What do I do if the water looks cloudy?</p>	<p>1. Make sure your filtration system is working properly (i.e. clean filter, skimmer and pump basket).</p> <p>2. Make sure circulation time is adequate – increase pump time if not.</p>	<p>3. Make sure the pool is properly balanced (see page 9).</p> <p>4. Shock the water to eliminate build up of any organic matter.</p> <p>5. Make sure pool has a</p>	<p>free chlorine reading of 1.0 to 3.0 ppm.</p> <p>6. Check with your dealer for more information.</p>
<p>2. What do I do if the water turns color?</p>	<p>1. Algae may be trying to form – shock the pool, increase circulation time if needed and clean the filter.</p>	<p>2. Metals in the fill water may have been oxidized. Have the pool tested. See pool dealer if a metal control product is required.</p>	<p>3. Check with your dealer for more information.</p>
<p>3. What do I do if algae forms in or on my pool?</p>	<p>1. Use an algaecide per the directions on the bottle and brush the sides of the pool often.</p>	<p>2. Clean the filter and shock the pool with chlorine daily until water clarity returns</p>	<p>3. Check with your dealer for more information.</p>
<p>4. What do I do if I am under chlorinating with the Sparco Chamber?</p>	<p>1. If you are unable to maintain at least 1.0 ppm, first make sure there are chlorine tablets in the tower areas of the Sparco Chamber and it is installed properly. If a correction was made, test the water in 24 hours.</p> <p>2. If still low, turn the dial up one setting and test the water again in 24 hours. Continue raising the setting by one increment each day until the proper reading is achieved.</p>	<p>3. Shock the pool if the reading has been lower than 1.0 ppm for more than one day.</p> <p>4. Make sure pump run time is at least 6 hours on high speed (40 gpm or higher) or if not, bleed the air from the cap knob each time cap is open.</p> <p>5. Contact your dealer to have your back pressure tested. If under 4 psi, consider a smaller eyeball fitting in the return jet.</p>	<p>6. Check for a suction side leak by looking for air bubbles in your pump basket or at the return jet. Contact dealer for help in correcting this situation.</p> <p>7. Contact King Technology's Customer Service Department at 800-222-0169.</p>
<p>5. What do I do if I am over chlorinating with the Sparco Chamber?</p>	<p>1. If the chlorine reading is over 3.0 ppm, remove the Sparco Chamber from the Sparco System and test the water daily until the reading is down to 1.0 ppm.</p> <p>2. Reinsert the Sparco Chamber, lower the dial one setting and test the water again in 24 hours. If the reading has risen, lower the dial one setting again. Continue this process until proper reading is achieved.</p>	<p>3. If over-chlorinating at the lowest possible setting, consider decreasing the circulation time. Depending on your pump size, you may be circulating the water more than is necessary.</p> <p>4. Contact your dealer to have your back pressure tested. If over 8 psi consider a larger eye-ball fitting in the return jet.</p>	<p>5. Check to see if the pressure relief valve is loose or missing and replace. It is a clear plastic piece approximately 1" long installed inside near the base. If loose or missing, it can provide another avenue for water to reach the chlorine.</p> <p>6. Contact King Technology's Customer Service Department at 800-222-0169.</p>

Parts List

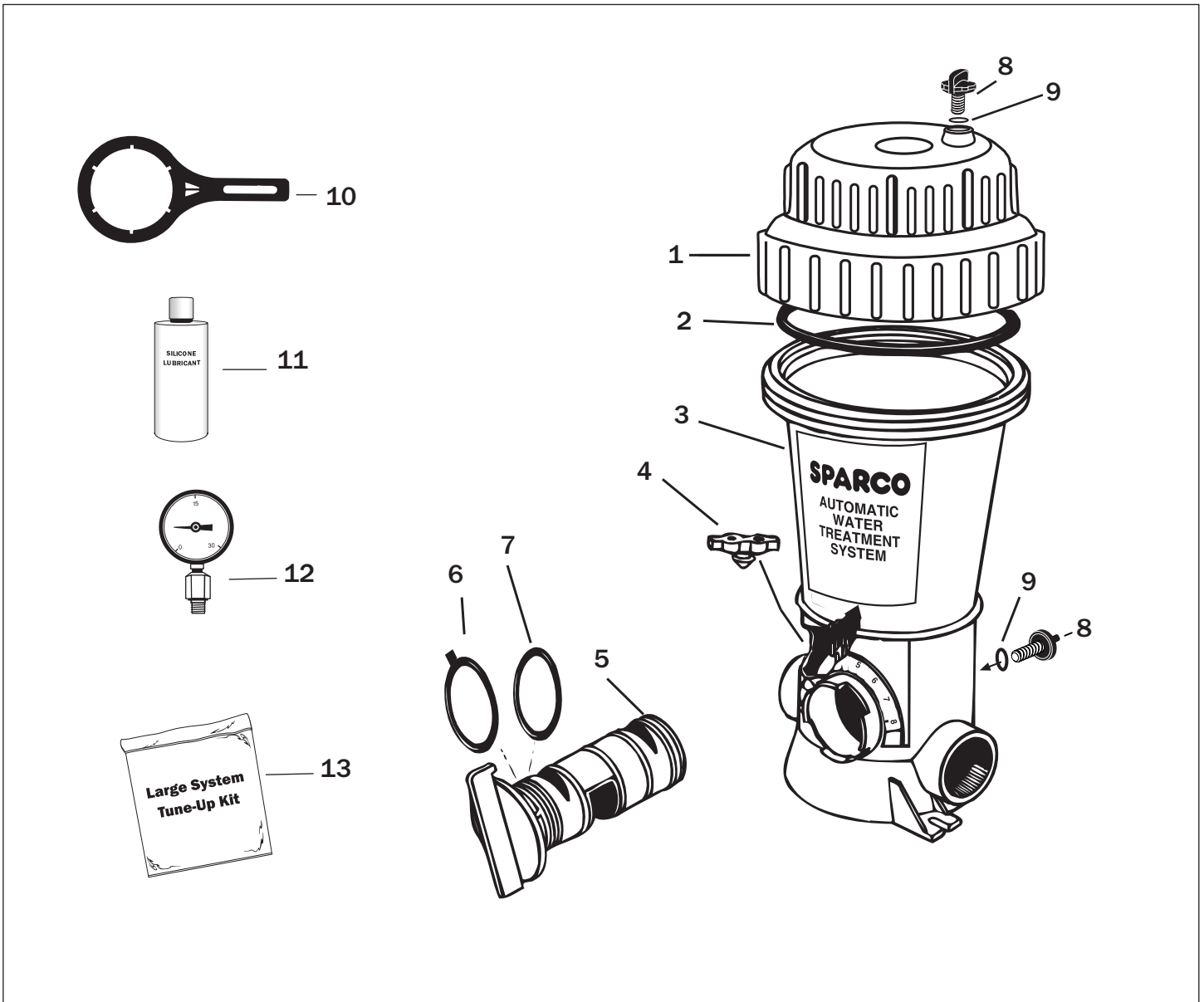

INCLUDED WITH SPARCO SYSTEM Model 5510

REF. #	DESCRIPTION	QTY. INCLUDED
1 & 2	Cap w/O-Ring	1
3	Body	1
4	Pressure Relief Valve	1
5, 6, 7	Control Dial with O-Rings	1
8 & 9	Knob with O-Ring	2
10	Cap/Control Dial Tool	1
11	Silicone Lubricant	1

REPLACEMENT PARTS FOR SPARCO SYSTEM Model 5510

REF. #	PART NUMBER	DESCRIPTION
1 & 2	01-22-9428	Cap w/O-Ring
2	01-22-9922	Cap O-Ring
3	N/A	Body
4	01-22-9485	Pressure Relief Valve
5, 6, 7	01-22-9446	Control Dial with O-Rings
6 & 7	01-22-9452	Control Dial O-Ring Kit
8 & 9	01-22-9945	Knob with O-Ring
10	01-22-8876	Cap/Control Dial Tool
11	01-22-9972	Silicone Lubricant 3/4 oz.
12	01-22-4000	Pressure Gauge
13	01-22-9950	Large System Tune Up Kit

System Maintenance

Replacing the Control Dial O-Rings

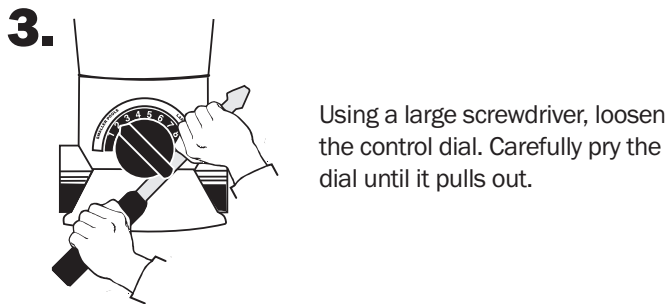
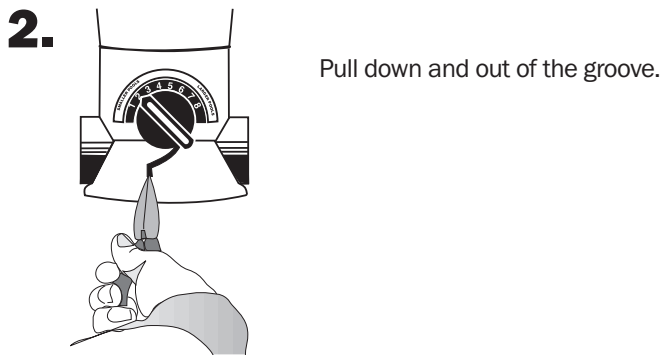
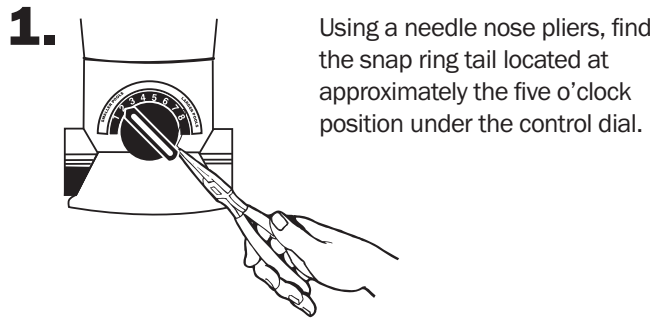

Product # 01-22-9972

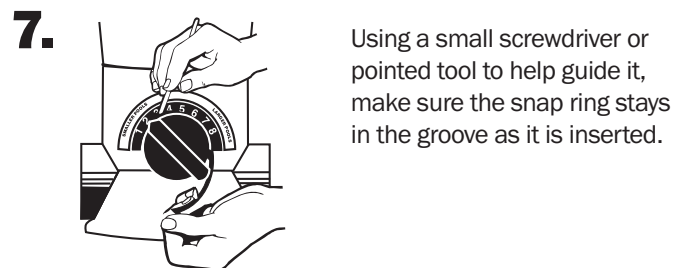
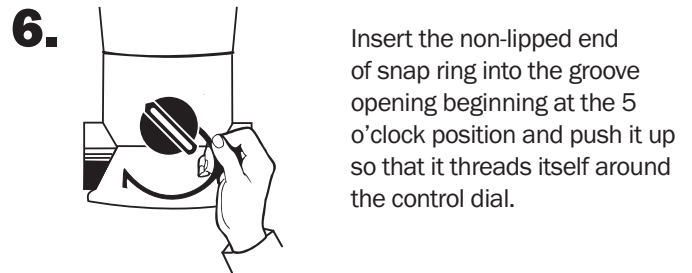
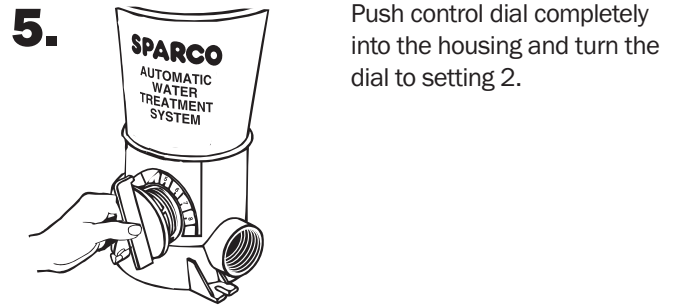

Replacing the Cap O-Ring

1. Remove old O-ring.

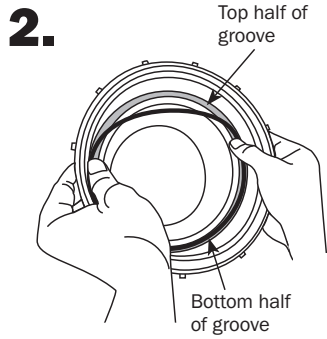

Place new O-ring in bottom half of groove.

Place your thumbs on each side of the cap over the O-ring in the groove.

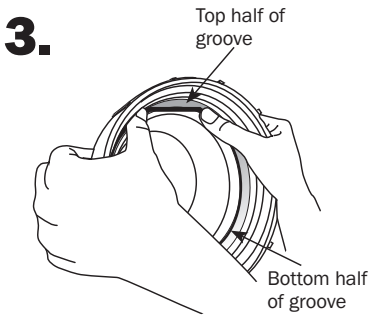

Roll your thumbs back and forth over the O-ring while pushing upward until the O-ring falls into the top of the groove.



Product # 01-22-9972

Lubricate O-ring every couple of months with silicone lubricant that came with your Sparco System.

DO NOT USE petroleum based lubricants.

Replacing Knobs

To replace, simply unscrew old knob and replace with the new one.

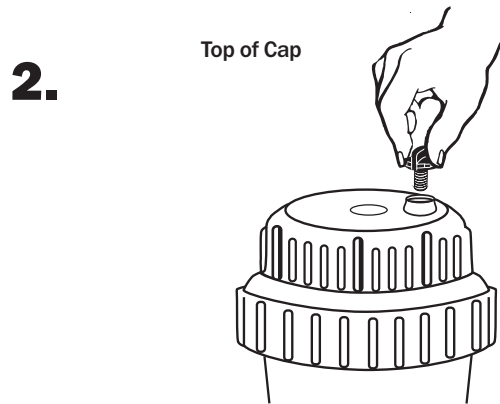
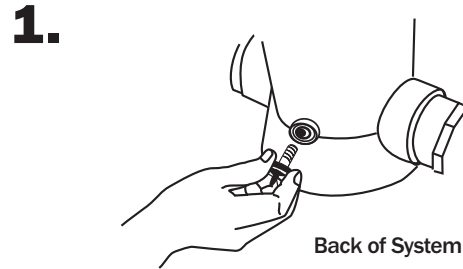

For limited warranty terms and to register your product,
see kingtechnology.com/reg or call 1-800-222-0169.

Failure to register your product does not diminish
your warranty rights.

Made in U.S.A.
Patents: kingtechnology.com/IP

MANUFACTURED FOR



6000 CLEARWATER DR | MINNETONKA, MINNESOTA 55343
800-222-0169 | kingtechnology.com

20-48-0150
1023R8