

Prevail® Cyclor Instruction Manual

Chlorine Pool-Care System
for Pools up to 25,000 Gallons



WARNING

To minimize the risk of serious injury, death or damage, before installing or first using this equipment, read Instruction Manual and all safety labels and follow all safety instructions and precautions. Save manual for future reference.

Customer Service 800-222-0169
kingtechnology.com

TABLE OF CONTENTS

Prevail Introduction	3
Notes and Safety Information	4
Safety Labels on Prevail Cyclor	5
Installation Tips to Ensure Proper Performance	6
Sand Filter Installation with Nipple Kit and Flex Hose	7
Sand Filter Installation with Flex Hose Only	8
DE and Cartridge Filter Installation With Flex Hose	9
Hard-Plumbed Installation	10
Step 1: Preparing the Pool	11
Step 2: Putting the System to Work	12
Step 3: Setting the Control Dial	13
Step 4: Routine Pool Care	14
Winterizing	15
Troubleshooting	16
Parts List	17
Maintenance - Replacing Control Dial O-Rings	18
Maintenance - Replacing Cap O-Rings and Knobs	18

For information on King Technology's entire product line, visit our website at kingtechnology.com

Prevail

Thank you for choosing Prevail. This system will maintain a clean, clear swimming pool while you spend less time on maintenance and more time having fun! There are two parts to the Prevail System:



Part 1: Prevail Cyclor 170

The water treatment center that controls the flow of water through the Prevail Pool Pack.
For pools up to 25,000 gallons
Product # 01-02-0170



Part 2: Prevail Pool Pack 70.5C

Prefilled with chlorine tablets and fits inside the Prevail Cyclor (Sold separately).
Product # 01-04-7413

Notes and Safety Information

General Notes

These instructions contain information for the safe and proper operation of this Prevail Cyclor. Observe the following principles:

- Ensure that everyone using this Prevail Cyclor follows the instructions and safety precautions.
- Keep the instructions nearby and available for reference throughout the service life of this Prevail Cyclor.

These instructions do not provide for every possible contingency that might be encountered in connection with installation, operation or maintenance of this equipment. Should further information be desired or should particular issues arise which are not covered sufficiently in this manual, contact King Technology at 800-222-0169.





Explanation of the signal words

Signal words, which depict the probability and severity of harm, are used in these instructions. They are defined as follows:

Signal Word	Meaning
DANGER	Indicates an imminently hazardous situation which, if not avoided, will result in death, serious injury or major property damage.
WARNING	Indicates a hazardous situation which, if not avoided, could result in serious injury, death, or major property damage.
NOTICE	Indicates special instructions that are important but not related to physical injury hazards.

Explanation of the safety pictographs

The following pictographs illustrate the type and source of a hazard.

Pictograph	Type of Danger
	Safety Alert/General Hazard
	Explosion Risk
	Hazardous Pressure
	Flammable Fire Hazard

Identification of warnings

Warnings are intended to help you recognize risks and avoid death, injury or property damage. This is how warnings are identified:

 Signal Word
Pictographs
<p>Description of danger. Consequences if ignored.</p> <p>⇒ The arrow signals a safety precaution to be taken to eliminate or reduce the risk.</p>

Safety Label on Cyclor

Review this label before installing or operating this Cyclor. Contact King Technology at 800-222-0169 if this label is missing from your Prevail Cyclor.



Fire, explosion and high pressure hazards

To minimize the risk of serious injury, death or property damage while using the Prevail Cyclor:

- ⇒ Read, understand and follow all instructions and safety precautions in the manual, and on this Cyclor and on any label for chemicals used with this Cyclor including Prevail Pool Packs.

DANGER

- ⇒ Never use fast dissolving chlorine tablets, liquid bleach, or calcium hypochlorite in the Prevail Cyclor.
- ⇒ Never mix Trichlor chlorine tablets with Calcium Hypochlorite, or with any other form of concentrated chlorine or other chemicals.
- ⇒ Never add any other types of chlorine or shock treatments through the skimmer. These products should be added directly into the pool if required.
- ⇒ Do not contaminate the Prevail Cyclor or Prevail Pool Packs with dirt, organic matter, pool chemicals (such as calcium hypochlorite or pool shocks), fertilizers or other household chemicals. Contact between any of these substances and the Prevail Cyclor and Prevail Pool Packs, will result in a chemical reaction with the generation of heat, liberation of hazardous gasses and fire or explosion.

WARNING

- ⇒ Use only Prevail Pool Packs in the Prevail Cyclor. Never use bulk chemicals.
- ⇒ To prevent the build up of gas pressure in the Prevail Cyclor, be sure the pool return line valves are open – except when opening or servicing the unit.
- ⇒ Do not inhale fumes from the Prevail Cyclor or Prevail Pool Packs.
- ⇒ Avoid sparks, smoking, or any open flame near Prevail Cyclor or chemicals.
- ⇒ Do not exceed maximum operating pressure of 50 psi or maximum temperature of 104° F.
- ⇒ Do not remove the cap while under pressure. Always turn off pump and bleed off pressure before opening Prevail Cyclor.
- ⇒ Do not install automatic or fast shut off valves downstream of Prevail Cyclor.
- ⇒ Always install the Prevail Cyclor AFTER a heater (if applicable) on the return line.
- ⇒ Always install any additional sanitizing equipment AFTER and NEVER BEFORE the Prevail Cyclor is installed on the return line.
- ⇒ Do not permit children to use or climb on this product. This product must be positioned to prevent children from using it as a means of access to the pool.
- ⇒ Always stand clear of the Prevail Cyclor during pump start-up.
- ⇒ Replace Prevail Cyclor if you see signs of cracks, damage or degradation to the Cyclor body or cap.

NOTICE

- ⇒ Prior to pressurizing, check with your dealer to ensure your plumbing connections meet building codes.
- ⇒ Failure to properly winterize your Prevail Cyclor could result in freeze damage. (See page 15 for winterizing details.)

Installation Tips to Ensure Proper Performance

Before installing, read all directions carefully and contact your dealer for installation support.



WARNING

- Do not exceed maximum operating pressure of 50 psi.
- Do not install automatic or fast shut off valves downstream of Prevail Cyclor.
- Always install the Prevail Cyclor AFTER the heater (if applicable) on the return line.
- Always install any additional sanitizing equipment AFTER and NEVER BEFORE the Prevail Cyclor is installed on the return line.

1) If using a multi-speed pump, run pump for at least 6 hours per day at high speed (at least 40 gpm).

If the pump will run on low speed 24 hours per day or less than 6 hours per day on high speed, you must bleed the air while the pump is on by unscrewing the back knob until water appears. Then screw the knob back in. Repeat this process each time the cap is removed for any reason.

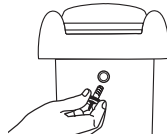

2) Install Cyclor with 4-8 psi back pressure.

Lower back pressures could result in under chlorination. Change the eyeball fittings in the return jets to a smaller size to increase back pressure. Contact King Technology at 800-222-0169 for a specially designed Cyclor pressure gauge to determine back pressure at pool start-up.



PN #01-22-4000

3) Special installation Requirements:

IMPORTANT: Over chlorination or damage to the Prevail Cyclor or other equipment could result if special installations A, B or C are not used in these situations.

- If water flow is higher than 80 gallons per minute (gpm), see diagram A.
- If an in-floor cleaner is included with pool, see diagram B, with two options. Preferred installation is Option 1 with two separate lines.
- If set-up is a pool and spa combination with common equipment, see diagram C.

Questions? Call Customer Service at 800-222-0169 Monday thru Friday, 8 am to 5 pm central standard time.

A. With High Flow Rate (greater than 80 gpm) Install T-fittings exactly as shown.

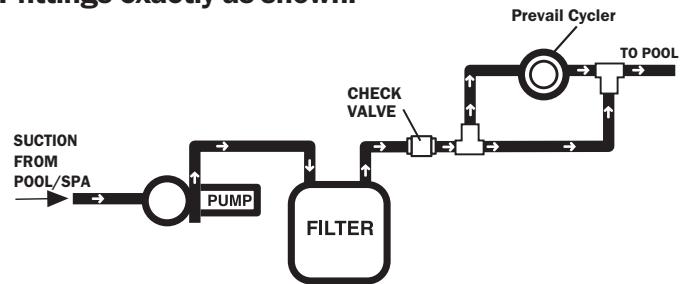

B. With In-Floor Cleaner - TWO OPTIONS

OPTION 1 - A Two-Line Installation

The best option is to have two lines. One line with pump, filter, heater and Prevail Cyclor and a second line with a separate pump for the in-floor cleaning system (filter optional).

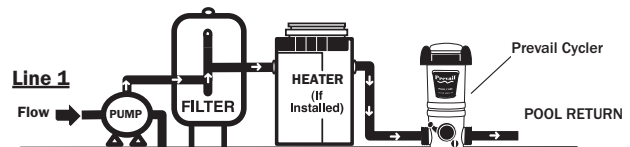

--- POOL WATER LEVEL
--- POOL WATER LEVEL

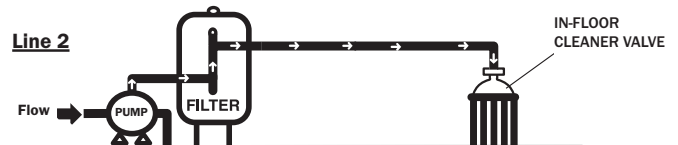

--- POOL WATER LEVEL

OPTION 2 - A 3-Way Valve Installation

3-way manual valve or 3-way motor valve plus controls

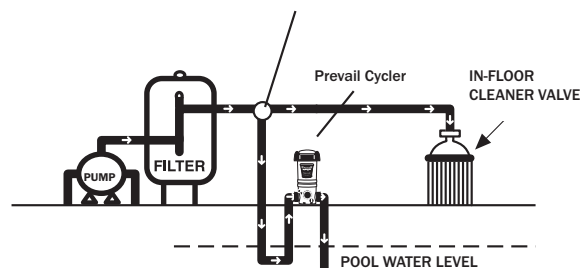

--- POOL WATER LEVEL

C. Pool and Spillover Spa Combination

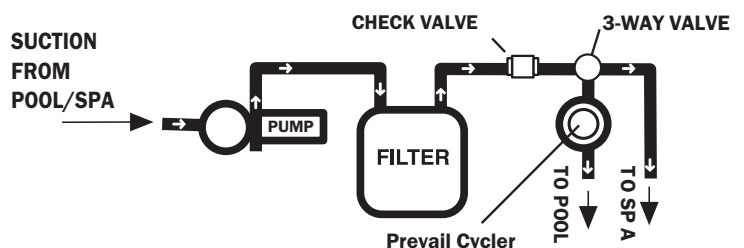

TOOLS NEEDED

Screwdriver



Pipe Wrench

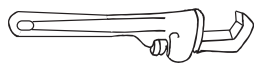

MATERIALS NEEDED

Pipe Thread Tape or Sealant

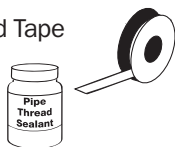

One 6" x 1 1/2" TBE PVC Nipple

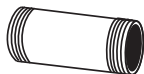

One Hose Adapter 1 1/2" X 1 1/2" X 1 1/4"



One Section of 1 1/2" or 1 1/4" Flex Hose (provided with filter)

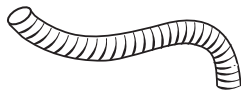

One Hose Clamp



RECOMMENDED

4-8 psi Back Pressure

To avoid over or under chlorination, replace eyeball fittings in the return jets to a smaller or larger size to adjust back pressure. For best results use King Technology's pressure gauge, order part number 01-22-4000.



Sand Filter Installation with Nipple Kit and Flex Hose

1. Apply pipe thread tape or sealant to each threaded end of nipple.

2. Screw one end of nipple into the filter return. Hand tighten. Finish tightening by turning 1 to 2 revolutions with a pipe wrench. **DO NOT OVER TIGHTEN.**

3. Screw either side of Prevail Cyclor on to open nipple end until upright and secure.

4. Apply pipe thread tape or sealant to threaded end of hose adapter.

5. Screw adapter into the other side of Prevail Cyclor. Hand tighten. Finish tightening by turning 1 to 2 revolutions with a pipe wrench. **DO NOT OVER TIGHTEN.**

6. Attach return section of hose to the adapter with clamp. Tighten clamp with screwdriver.

7. To prevent damage to heaters or filters, see your dealer about installing a **corrosion resistant check valve** which will reduce the back flow of chlorine gas when the Prevail Cyclor is turned off.

TOOLS NEEDED

Screwdriver



Pipe Wrench

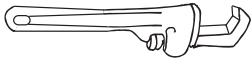

MATERIALS NEEDED

Pipe Thread Tape
or Sealant

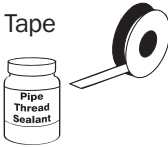

Two hose adapters
1 1/2" X 1 1/2" X 1 1/4"



Two Sections of 1 1/2"
or 1 1/4" Flex Hose (one
provided with filter)

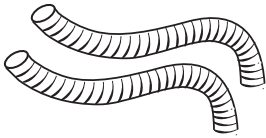

Two
Hose
Clamps



RECOMMENDED

4-8 psi Back Pressure

To avoid over or under chlorination, replace eyeball fittings in the return jets to a smaller or larger size to adjust back pressure. For best results use King Technology's pressure gauge, order part number 01-22-4000.



Sand Filter Installation with Flex Hose Only

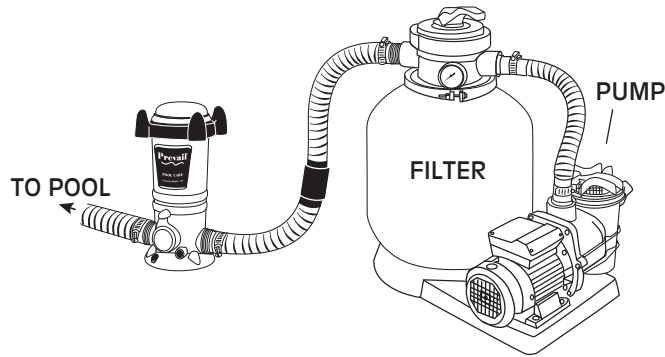

The Prevail Cyclizer should always be installed between the filter and pool (or between heater and pool if applicable). Never install Prevail Cyclizer before the heater or damage to the heater could occur.

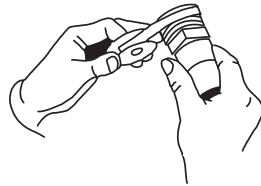

1. Apply pipe thread tape or sealant to the threaded end of both hose adapters.

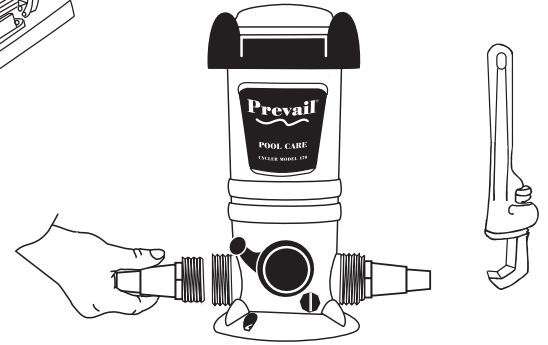

2. Screw adapters into each end of Prevail Cyclizer. Hand tighten. Finish tightening by turning 1 to 2 revolutions with pipe wrench. **DO NOT OVER TIGHTEN.**

3. Attach the filter section of flex hose to one hose adapter and the return section of flex hose to the other hose adapter with clamps and tighten with screwdriver. Bi-flow valve design allows water flow installation in either direction.

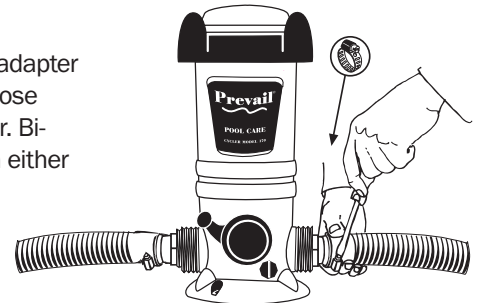

4. To prevent damage to heaters or filters, install a **corrosion resistant check valve** which will reduce the back flow of chlorine gas when the system is turned off.

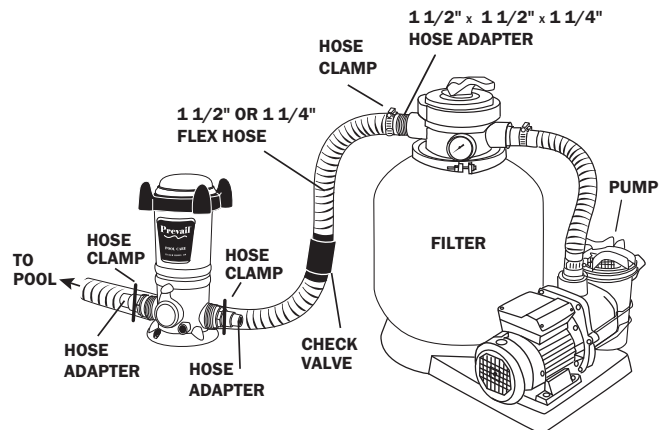

5. For better stability, Prevail Cyclizer may be mounted on a treated wood base using **Phillips pan head screws**, one in front and two in back. If you have questions about stability, please contact your dealer or King Technology.

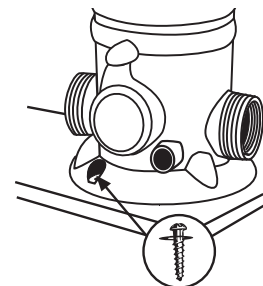

TOOLS NEEDED

Screwdriver

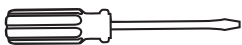

Pipe Wrench

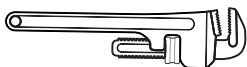

MATERIALS NEEDED

Pipe Thread Tape or Sealant

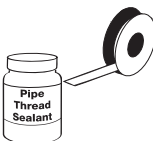

Two Hose Adapters
1 1/2" X 1 1/2" X 1 1/4"



Two Sections of 1 1/2" or 1 1/4" Flex Hose

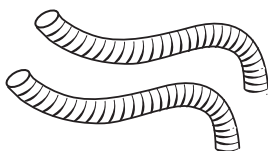

Two Hose Clamps



RECOMMENDED

4-8 psi Back Pressure

To avoid over or under chlorination, replace eyeball fittings in the return jets to a smaller or larger size to adjust back pressure. For best results use King Technology's pressure gauge, order part number 01-22-4000.



DE and Cartridge Filter Installation With Flex Hose

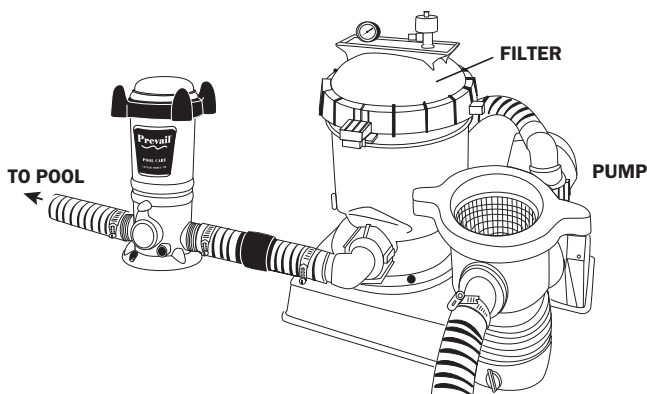

The Prevail Cyclor should always be installed between the filter and pool (or between heater and pool if applicable). Never install Prevail Cyclor before the heater or damage to the heater could occur.

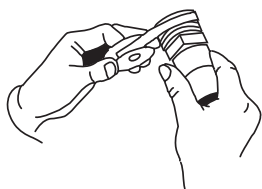

1. Apply pipe thread tape or sealant to the threaded end of both hose adapters.

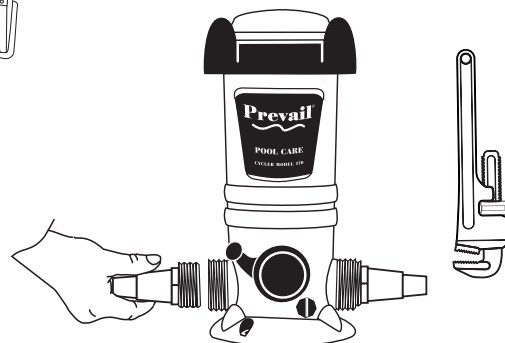

2. Screw adapters into each end of Prevail Cyclor. Hand tighten. Finish tightening by turning 1 to 2 revolutions with a pipe wrench. **DO NOT OVER TIGHTEN.**

3. Attach the filter section of flex hose to one hose adapter and the return section of flex hose to the other hose adapter with clamps and tighten with screwdriver. Bi-flow valve design allows water flow in either direction.

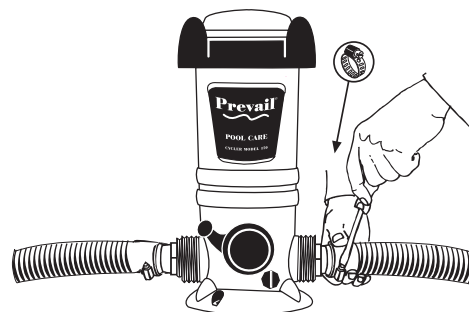

4. To prevent damage to heaters or filters, see your dealer about installing a **corrosion resistant check valve** which will reduce the back flow of chlorine gas when the Prevail Cyclor is turned off.

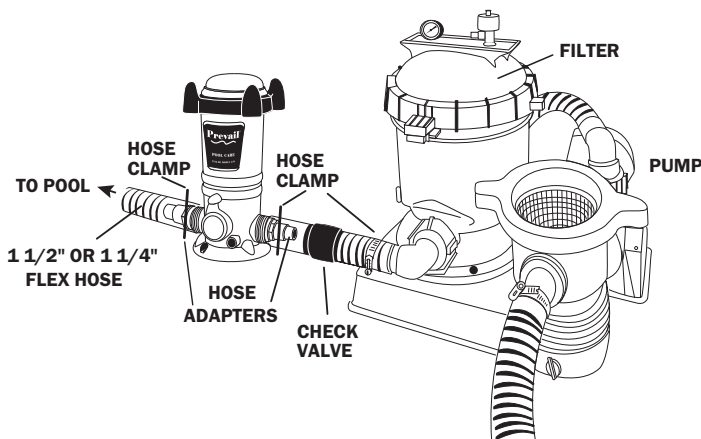

5. For better stability, Prevail Cyclor may be mounted on a treated wood base using **Phillips pan head screws**, one in front and two in back. If you have questions about stability, please contact your dealer or King Technology.

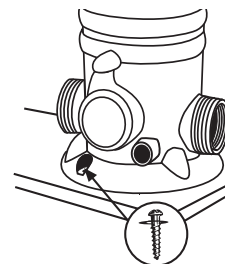

TOOLS NEEDED

Pipe Wrench

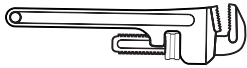

Hacksaw

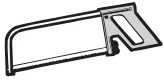

Tape Measure

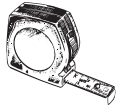

MATERIALS NEEDED

Pipe Thread Tape or Sealant and Primer and PVC Cement

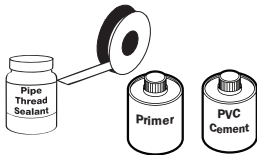

1½" Male Adapter (slip x MPT)



or

2" Female Adapter (slip x FPT)



SECURE CYCLER

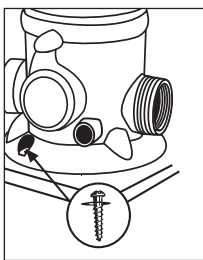

For better stability, Prevail Cyclier may be mounted on a treated wood base using **Phillips pan head screws**, one in front and two in back. If you have questions about stability, please contact your dealer or King Technology.

Hard-Plumbed Installation

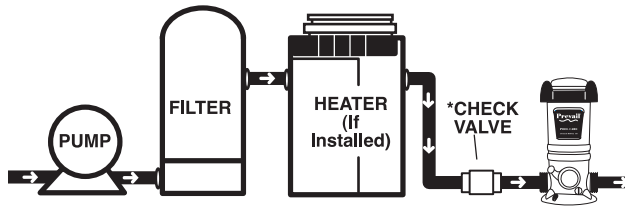

The Prevail Cyclier should always be installed between the filter and pool (or between heater and pool if applicable). Never install Prevail Cyclier before the heater or damage to the heater could occur.



Do NOT install in copper pipe as chemical corrosion may lead to pipe failure.



Do NOT install Prevail Cyclier off-line.

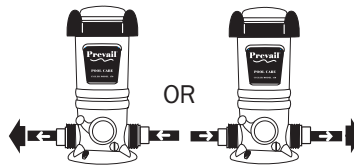

Bi-flow valve design allows installation in either flow direction.

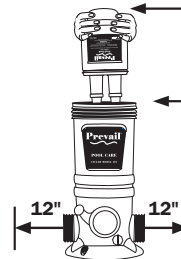

12" Allow a minimum of 12" above and on each side of Prevail Cyclier to ensure room for replacement of Prevail Pool Pack.

1. Screw adapters into each end of Prevail Cyclier following directions for a male adapter or a female adapter. Hand tighten. Finish tightening by turning 1 to 2 revolutions with a pipe wrench. **DO NOT OVER TIGHTEN.**

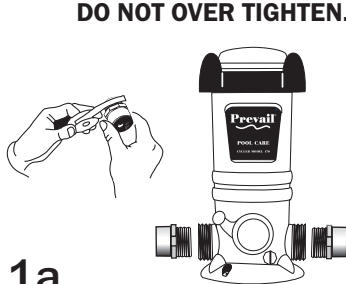

1a.

If using **male adapters**, apply pipe thread tape or sealant to the threaded end of each adapter.

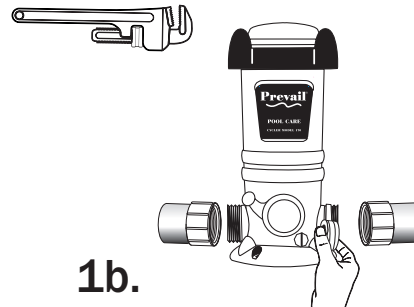

1b.

If using **female adapters**, apply pipe thread tape or sealant to the threaded end of each Cyclier port.

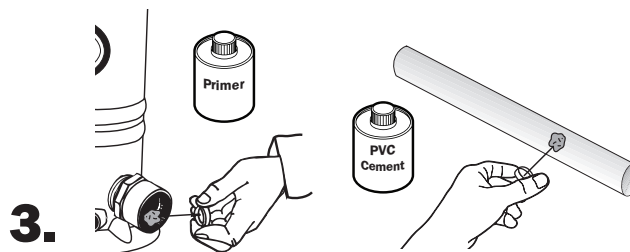
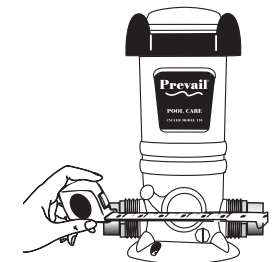

3.

Following primer directions, brush primer on the inside of the adapters and to ends of pipe. Repeat this process with PVC cement following directions on that product.

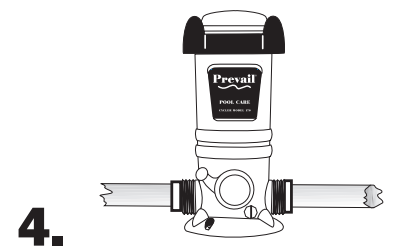

4.

Insert PVC pipe into adapters with a twisting action. Hold in place 5 to 10 seconds to bond.

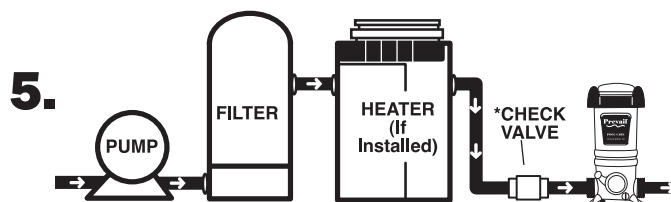



5.

To prevent damage to heaters or filters, see your dealer about installing a **corrosion resistant check valve** which will reduce the back flow of chlorine gas when the Prevail Cyclier is turned off.

Step 1: Preparing the Pool

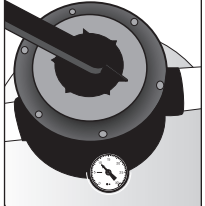
1.  Make sure the pool has adequate circulation. The total volume of pool water must completely circulate through the pump and filter at least 1 to 2 times per day. This usually requires 8 to 12 hours of circulation. Check with your dealer for the proper circulation time for your pool.

2.  Check the pool's filter gauge often and periodically clean filter per the manufacturer's directions. A dirty filter will slow the flow of water which could hamper proper circulation.



WARNING
Do not exceed maximum operating pressure of 50 psi.

3. Check the Water Hardness of your fill water before adding to the pool. If calcium content is higher than 400 ppm, find a soft water source to fill your pool instead; otherwise water balance will be very difficult.

4.  Check for metals in the pool such as iron or copper. Before attempting water balance, these should be removed. See your dealer for a metal out or sequesterant and follow the label directions carefully.

5. Before beginning with any pool care program, you must first balance your pool water. Take a water sample to your local pool professional (or use a complete test kit) to test for the important Water Balance Guidelines.

IMPORTANT: Always follow printed instructions on the balancing chemical packages. Add balancing chemicals in small increments one at a time with circulation running. **For best results, wait 8-12 hours** before testing again and adding any additional balancing chemicals.

Water Balance Guidelines

pH:	7.2 – 7.8
Total Alkalinity:	80 – 120 ppm
Hardness:	200 – 400
Total Dissolved Solids:	<1500
Stabilizer:	20 – 80 ppm
Free Chlorine:	0.5 – 1.0 ppm

For best results in achieving water balance, follow steps **5a through 5e** in order.

5a. Take a water sample from the pool and dip a test strip into it.

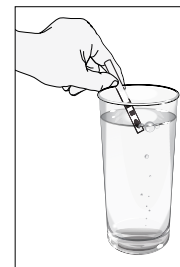

5b. Look at the **Total Alkalinity** reading first. Adjustments should be made to bring the Total Alkalinity in the range of **80 – 120 ppm** prior to making any adjustments to pH even if it throws pH off further.

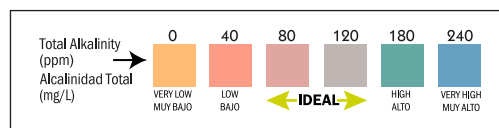

5c. After Total Alkalinity is in range, test for **pH**. It should be between **7.2 and 7.8**. If higher or lower, add a pH adjuster.

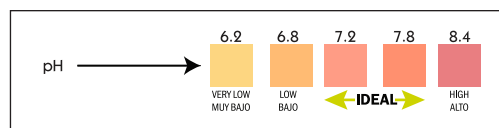

5d. Then test your Water Hardness again. If lower than 200 ppm, add Calcium Increaser. Always maintain 200-400 ppm.

5e. Lastly test for **stabilizer or conditioner levels**. Add conditioner if the level is below 20 ppm. This will prevent chlorine burn off. If stabilizer level is above 80 ppm, partially drain water and re-fill.

6.  Initially shock the pool with a **chlorine shock only** to rid the water of contaminants and establish a chlorine residual. Always follow the manufacturer's directions carefully. See the DANGER box below for important guidance on shocking.



DANGER

- Never add any other types of chlorine or shock treatments through the skimmer. These products should be added directly into the pool if required.
- Never use fast dissolving chlorine tablets, liquid bleach, or calcium hypochlorite in the Preval Cyclor

Step 2: Putting the System to Work



DANGER

Never use fast dissolving chlorine tablets, liquid bleach, or calcium hypochlorite in the Prevail Cyclor.



WARNING

Avoid sparks, smoking, or any open flame near Prevail Cyclor or chemicals.

IMPORTANT: Read the label on the Prevail Pool Pack carefully before using.

1.

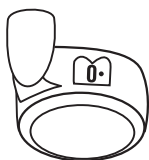

Turn off pump. Turn dial to 0. This reduces the flow of water into the unit when the cap is open.

2.



Open the cap. Stand back to allow any chlorine fumes to dissipate.

3.

Cut handle from Prevail Pool Pac using a PVC cutting tool (KEEP OUT OF REACH OF CHILDREN)

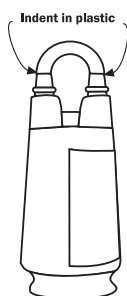

3A. Find the indent in the plastic.



PVC cutting tool available at local hardware stores.

3B. Place curved section of tool around the narrow end of one pack tower and line up blade on indent

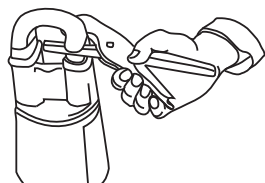

3C. Squeeze the handles together. Repeat for other side.

Finished cut ends



3D. Make sure the blade comes straight across on the indent line for a clean cut.

3E. If openings are pinched together, open with fingers or re-cut closer to the colored screens inside Prevail Pool Pack. Leave at least 1/4" of plastic to fit into Prevail Cyclor base.

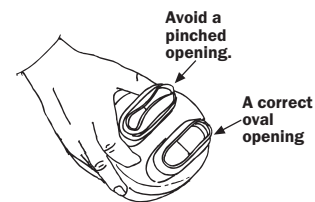

4.

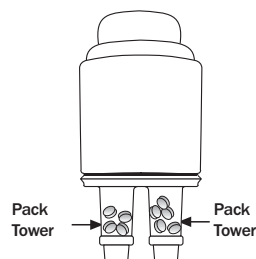

Invert Prevail Pool Pack and shake slightly until chlorine tablets fall into tower areas.

5.



Insert Prevail Pool Pack into Prevail Cyclor, lining up the openings in Prevail Pool Pack with keys in Prevail Cyclor.

NOTE: Openings are a different shape than keys.

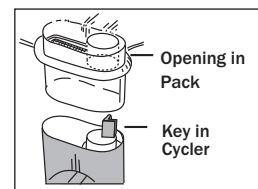

6.



Replace cap by hand only. **DO NOT OVERTIGHTEN.**

7.



The Prevail Pool Packs are made of HDPE plastic. Non-refillable container. Do not reuse or refill this container. Offer for recycling if available. Rinse thoroughly before recycling or discarding in trash.

8.



Mark calendar ahead for the approximate replacement times for the Prevail Pool Pack.

Step 3: Setting Control Dial

This system is designed to work effectively with a variety of pool equipment as long as the following procedures are followed.

- Set control dial on Prevail Cycler by matching up the parameters of your pool on the chart below. THIS IS A STARTING POINT ONLY and may need to be adjusted to fit your individual pool needs. See #2 below for adjusting directions.
IMPORTANT: If using a multi-speed pump, pump-run times of at least 6 hours per day at high speed are recommended for proper performance. **If running the pump at low speed only or on high speed less than 6 hours, please follow the 24 hour low-speed directions below.**

POOL SIZE		SINGLE-SPEED PUMP OR HIGH-SPEED PUMP RUN TIME											
		8 HOUR PUMP RUN TIME				12 HOUR PUMP RUN TIME				24 HOUR PUMP RUN TIME			
		Gallons	Diameter	PUMP SIZE				PUMP SIZE				PUMP SIZE	
		1/2 hp	3/4 hp	1 hp	1 1/2 hp	1/2 hp	3/4 hp	1 hp	1 1/2 hp	1/2 hp	3/4 hp	1 hp	1 1/2 hp
7,000	(18')	4.5	4.0	3.5	3.0	2.5	2.0	1.0	3.0^	1.5	1.0	1.0	2.0^
9,000	(21')	5.0	4.5	4.0	3.5	3.0	2.5	2.0	3.5^	2.0	1.5	1.0	2.5^
12,000	(24')	5.5	5.0	4.5	4.0	3.5	3.0	2.5	2.0	2.5	2.0	1.5	3.0^
18,000		NR	5.5	5.0	4.5	4.0	3.5	3.0	2.5	3.0	2.5	2.0	1.5
20,000		NR	NR	5.5	5.0	4.5	4.0	3.5	3.0	3.5	3.0	2.5	2.0
25,000		NR	NR	6.0	5.5	5.0	4.5	4.0	3.5	4.0	3.5	3.0	2.5

^ Bypass installation recommended. See "Installation Tips" on page 6. NR - This pump size is not recommended for this size pool.

24 HOUR, LOW-SPEED PUMP RUN TIME

In order to ensure proper performance when running the pump on low speed for 24 hours per day or high speed less than 6 hours per day, bleed the air while the pump is on by unscrewing the back knob until water appears. Then screw the knob back in. Repeat this process each time the cap is removed for any reason. Set the control dial at 6 and follow the adjustment directions in Step 2 to determine the correct setting for your pool.

EXAMPLE

POOL SIZE		12 HOUR PUMP RUN TIME			
		Gallons	Diameter	PUMP SIZE	
		1 hp	3/4 hp	1 hp	1 1/2 hp
7,000	(18')	2.5	2.0	1.0	3.0^
9,000	(21')	3.0	2.5	2.0	3.5^
12,000	(24')	3.5	3.0	2.5	2.0
18,000		4.0	3.5	3.0	2.5
20,000		4.5	4.0	3.5	3.0
25,000		5.0	4.5	4.0	3.5

Find your starting dial setting by matching up the parameters of your pool on the above chart. An above ground pool with approximately 12,000 gallons, with a 1 horsepower pump running 12 hours a day, would require a starting setting of 2.5.

2.

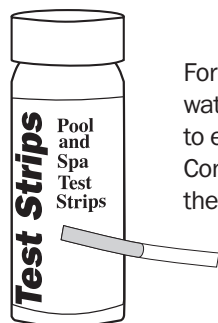

For the first week, test the pool water daily for free chlorine to ensure correct dial setting. Continue to test weekly throughout the season..

After each testing, adjust the dial up by 1/2 increment if the free chlorine reading has dropped or down by 1/2 increment if the reading has risen. Continue this process each day until the reading stabilizes at your desired level between 1.0- 3.0 ppm. Remember to adjust dial by 1/2 increments only.



IMPORTANT: Control dial settings in excess of these recommendations could result in excess trichlor levels being discharged into the pool. This can result in bleaching or discoloration of areas around the pool inlet or in some cases bleaching or discoloration of the entire pool liner or paint. In addition, excess trichlor in the pool can create health hazards to bathers.

Step 4: Routine Pool Care

1.



Run filtration system enough hours to circulate all water 1 to 2 times per day. More than that could result in over chlorination.



WARNING

To prevent the build up of gas pressure in the Prevail Cyclor, be sure the pool return line valves are open except when opening or servicing the unit.

2.



Regularly test water to maintain pH and Total Alkalinity.

NOTE: Water balance is affected by bather load, chemical usage, evaporation and the makeup of source water, so maintaining water balance regularly is important.

3.

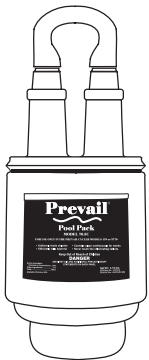

Maintain 1.0 - 3.0 ppm free chlorine level at all times.



DANGER

Do not contaminate the Prevail Cyclor or Prevail Pool Packs with dirt, organic matter, pool chemicals (such as calcium hypochlorite or pool shocks), fertilizers or other household chemicals. Contact between any of these substances and the Prevail Cyclor or Prevail Pool Packs, will result in a chemical reaction with the generation of heat, liberation of hazardous gasses and fire or explosion.

4.

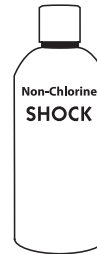

Shock the pool every week or as needed with a chlorine or a non-chlorine shock.



DANGER

- Never add any other types of chlorine or shock treatments through the skimmer. These products should be added directly into the pool if required.
- Never use fast dissolving chlorine tablets, liquid bleach, or calcium hypochlorite in the Prevail Cyclor.

Winterizing



1. Turn pump off.

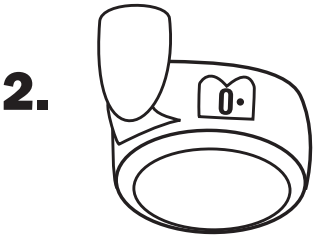

2. Turn dial to Setting 0.



3. Remove cap.

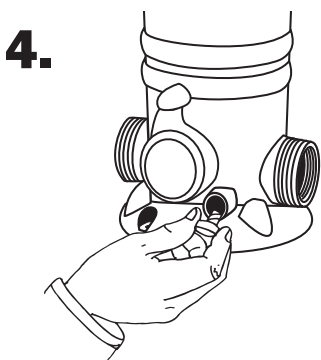

Unscrew knob from the front of Prevail Cyclers. Allow all water to drain.

5.



Remove Prevail Pool Pack



If Pack still contains chlorine, wrap in plastic bag and store in shed or cool, dry, well-ventilated location away from children, pets, cars, motorcycles or anything metal that can rust, pit, etc.

If empty, rinse and recycle.



WARNING

Avoid sparks, smoking, or any open flame near Prevail Cyclers or chemicals.

6. Replace the cap and knobs loosely.

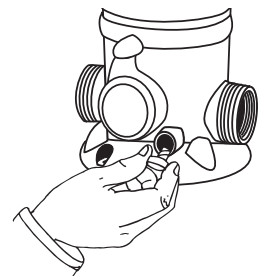
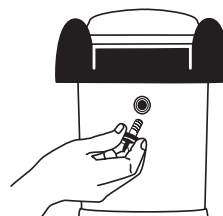

Troubleshooting

For help in troubleshooting call King Technology at 800-222-0169.

Problem	Remedy		
<p>1. What do I do if the water looks cloudy?</p>	<p>1. Make sure your filtration system is working properly (i.e. clean filter, skimmer and pump basket).</p> <p>2. Make sure circulation time is adequate – increase pump</p>	<p>time if not.</p> <p>3. Make sure the pool is properly balanced (see page 10).</p> <p>4. Shock the water to eliminate build up of any organic matter.</p> <p>5. Make sure pool has a</p>	<p>free chlorine reading of 1.0 to 3.0 ppm.</p> <p>6. Check with your dealer for more information.</p>
<p>2. What do I do if the water turns color?</p>	<p>1. Algae may be trying to form – shock the pool, increase circulation time if needed and clean the filter.</p>	<p>2. Metals in the fill water may have been oxidized. Have the pool tested. See pool dealer if metal control product is required.</p>	<p>3. Check with your dealer for more information.</p>
<p>3. What do I do if algae forms in or on my pool?</p>	<p>1. Use an algacide per the directions on the bottle and brush the sides of the pool often.</p>	<p>2. Clean the filter and shock the pool with chlorine daily until water clarity returns</p>	<p>3. Check with your dealer for more information.</p>
<p>4. What do I do if I am under chlorinating with the Prevail Pool Pack?</p>	<p>1. If you are unable to maintain at least 1.0 ppm, first make sure there are chlorine tablets in the tower areas of the Prevail Pool Pack and it is installed properly. If a correction was made, test the water in 24 hours.</p> <p>2. If still low, turn the dial up one setting and test the water again in 24 hours. Continue raising the setting by one increment each day until the proper reading is achieved.</p>	<p>3. Shock the pool if the reading has been lower than 1.0 ppm for more than one day.</p> <p>4. Make sure pump run time is at least 6 hours on high speed (40 gpm or higher) or if not, bleed the air from the back knob each time the cap is opened.</p> <p>5. Contact your dealer to have your back pressure tested. If under 4 psi, consider a smaller eyeball fitting in the return jet.</p>	<p>6. Check for a suction side leak by looking for air bubbles in your pump basket or at the return jet. Contact dealer for help in correcting this situation.</p> <p>7. Contact King Technology's Customer Service Department at 800-222-0169.</p>
<p>5. What do I do if I am over chlorinating with the Prevail Pool Pack?</p>	<p>1. If the chlorine reading is over 3.0 ppm, remove the Prevail Pool Pack from the Prevail Cycler and test the water daily until the reading is down to 1.0 ppm.</p> <p>2. Reinsert the Prevail Pool Pack, lower the dial one setting and test the water again in 24 hours. If the reading has risen, lower the dial one setting again. Continue this process until proper reading is achieved.</p>	<p>3. If over-chlorinating at the lowest possible setting, consider decreasing the circulation time. Depending on your pump size, you may be circulating the water more than is necessary.</p> <p>4. Contact your dealer to have your back pressure tested. If over 8 psi consider a larger eye-ball fitting in the return jet.</p> <p>5. Check to see if the pressure relief valve is loose or missing</p>	<p>and replace. It is a clear plastic piece approximately 1" long installed inside near the base. If loose or missing, it can provide another avenue for water to reach the chlorine.</p> <p>6. Contact King Technology's Customer Service Department at 800-222-0169.</p>

Parts List

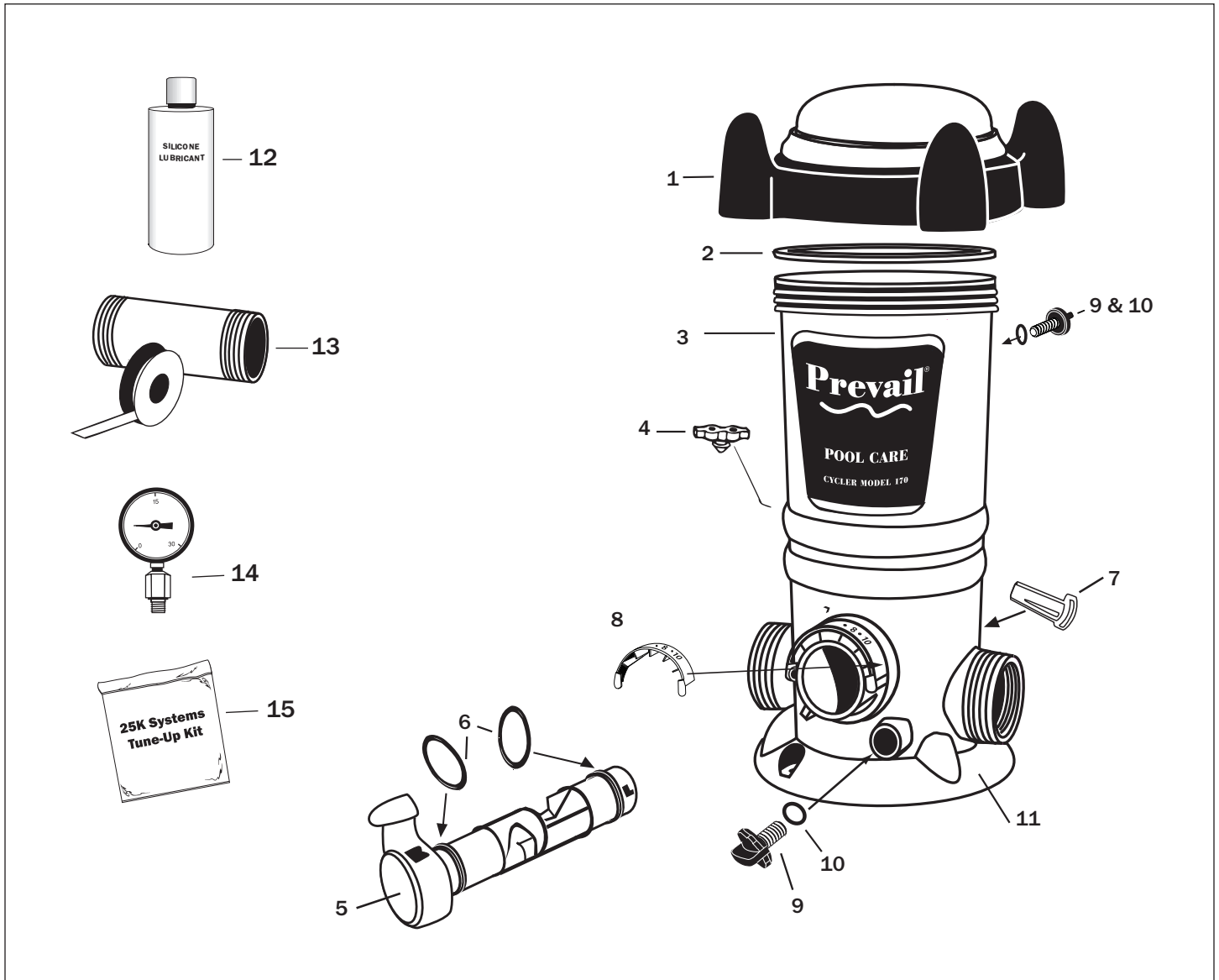

Troubleshoot

Included with Prevail Cyclor 170

REF. #	DESCRIPTION	QTY. INCLUDED
1 & 2	Cap w/O-Ring	1
3	Body	1
4	Pressure Relief Valve	1
5, 6, 7, 8	Control Dial with O-Rings, Locking Pin and Number Plate	1
9 & 10	Knob with O-Ring	2
11	Mounting Base	1
12	Silicone Lubricant	1

Replacement Parts for Prevail 170

REF. #	PART NO.	DESCRIPTION
1 & 2	01-22-1410	Cap w/O-Ring
2	01-22-1922	Cap O-Ring
4	01-22-9485	Pressure Relief Valve
5, 6, 7, 8	01-22-1446	Control Dial with O-Rings Locking Pin and Number Plate
	01-22-1456	Control Dial O-Ring Set
9 & 10	01-22-9945	Knob with O-Ring
11	01-22-1480	Mounting Base
12	01-22-9972	Silicone Lubricant
13	01-22-1711	Nipple Kit
14	01-22-4000	Pressure Gauge
15	01-22-1470	25k Tune-Up Kit

Cycler Maintenance

Replacing the Control Dial O-Rings

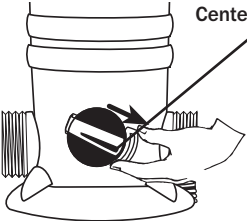
1.  Center of locking pin

In the back of the Prevail Cycler depress center of locking pin with a finger and pull pin out of dial.

2. 

Turn control dial back and forth as you pull it out of the housing.

3. 

Replace both O-rings. Apply silicone lubricant that came with your Prevail Cycler on O-rings.



Product #
01-22-9972

4. 

Carefully insert control dial back into housing.

5. 

Replace locking pin by pushing it through the slots on the dial until it locks into place.

Replacing Cap O-Ring

1. Remove old O-ring.

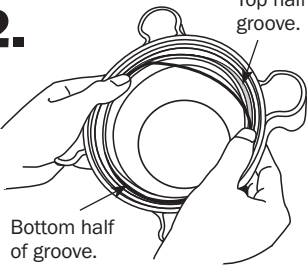
2.  Top half of groove.

Place new O-ring in bottom half of groove.

Bottom half of groove.

3. 

Place your thumbs on each side of the cap over the O-ring in the groove.

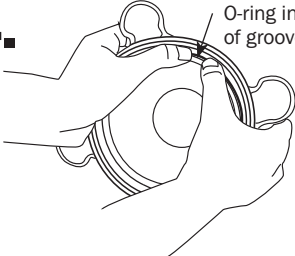
4.  O-ring in top of groove

Roll your thumbs back and forth over the O-ring while pushing upward until the O-ring falls into the top of the groove.



Product #
01-22-9972

Lubricate O-ring often with silicone lubricant that came with your Prevail Cycler. **DO NOT USE** petroleum based lubricants.

Replacing Cycler Knobs

To replace, simply unscrew old knob and replace with the new one.

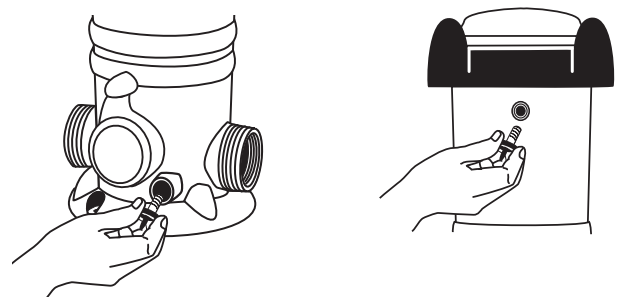

For limited warranty terms and to register your product,
see kingtechnology.com/reg or call 1-800-222-0169.

Failure to register your product does not diminish
your warranty rights.

Made in U.S.A.
Patents: kingtechnology.com/IP

MANUFACTURED FOR



6000 CLEARWATER DR | MINNETONKA, MINNESOTA 55343
800-222-0169 | kingtechnology.com